

ZET-Horn 90/110 AC

General Features

The ZÖLLNER ZET-Horn was the first piston type whistle on the world market driven by an AC 3phase motor. An essential component is the piston inside the cylinder driven by an AC 3phase motor via connecting rod, crankshaft and gearwheels. The piston oscillates at a certain frequency which makes the air inside the sound projector vibrate in resonance to produce a clean sound audibel over a wide range.



Essentials

- full compliance with the Colregs 1972, Annex III
- type approved by all wellknown international authorities and classification societies
- application:
 - vessels of class I, 200 m ore more in length
 - land alarm, i.e. bunker stations, oil refineries, airports, power plants, factories
- system voltage: AC 3phase/control box AC 1ph.
- entirely made of best non-corrosion, seawater-resistant materials
 - gearwheels made of wear-resistant upgraded steel (no plastic!)

Sound Characteristics

- broad frequency spectrum with many higher harmonics
- signals with strong overtones for best penetration of background noise level
 - Even when a background noise covers the actual basic frequency the residual tone forms a parent frequency in the human hearing. Two or three harmonics are sufficient for the hearing to perceive the basic frequency.*
- sound frequency of 90 Hz / 110 Hz very advantageously ranks in the lower admissable range (70-200Hz)
- sound pressure level 143 dB in 1/3rd octave band at 1 m distance

Advantages

- *decades of experience*
- *best material and workmanship - made in Germany*
- *entirely made of best non-corrosion, seawater-resistant materials*
- *simple but maturated design*
 - *easy exchange of all parts with onboard tools*
 - *steady lubrication with standard grease (no oil!)*
- *cylinder suspended vertically for optimum discharge of spray, flood, condensation water or melted snow*
- *motor heating to avoid condensed water included as a standard,*
 - *no additional cable required!*
- *easy installation*
 - *only one three-core cable required for connection to board mains!*
 - *relatively low weight*
 - *not affected by voltage and frequency fluctuations of board mains*

Positioning and installation

- Positioning as high as practicable on the vessel to reduce interception of the emitted sound by obstructions and to avoid hearing damage risk to the personnel.
- The sound pressure level of a vessel's own signal at listening posts must not exceed 110 dB(A).

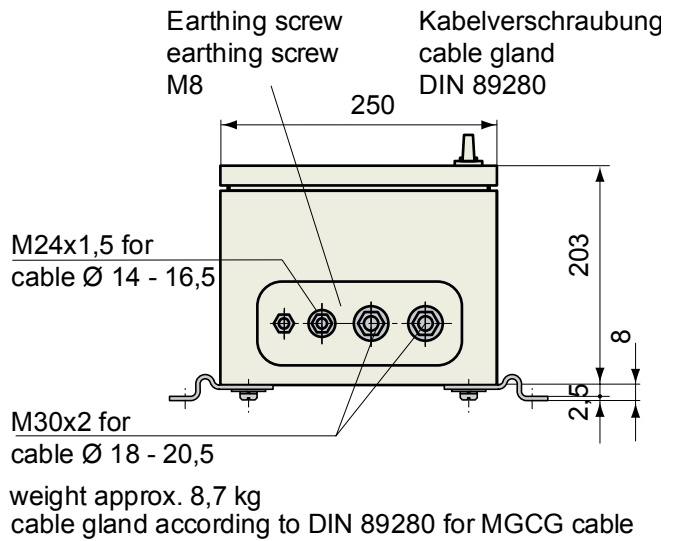
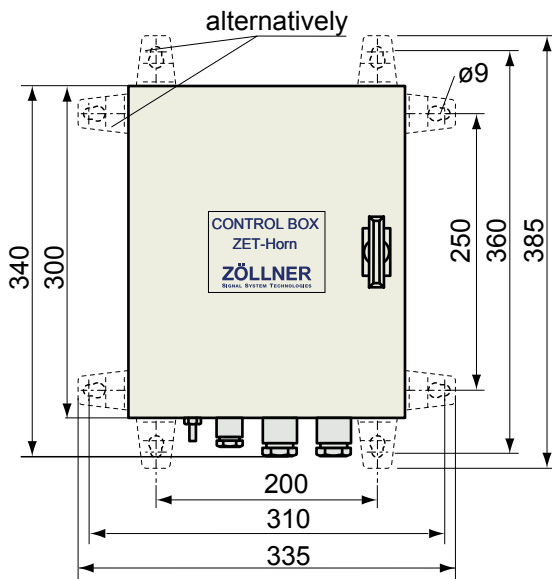
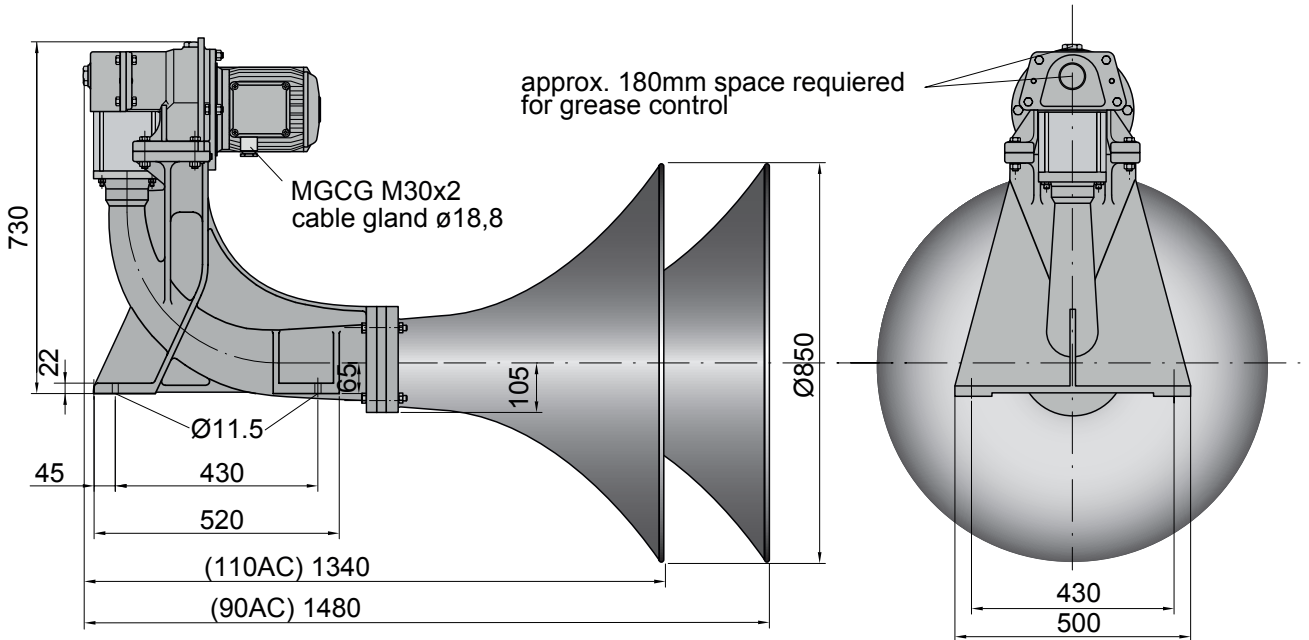

type	ship length [m]	current frequency		cable gland [mm] max.	fundamental frequency [Hz]	sound intensity in 1/3rd-octave band level at 1 m distance		motor output [kW]	motor heating up to [W]	type approval BSH(DHI) no.	protection type	weight [kg]
		50Hz	60Hz			dB(A)	min. IMO 1/3rd oct					
90AC	>200	.. /5	.. /6	ø15/ ø18,8	90	146	143 dB	5,5	250	4615/6021094/09	IP 56	92
110AC	>200	.. /5	.. /6		110	143	143 dB	5,5	250	4615/6021095/09	IP 56	90

Subject to alteration!